

Possible type of female part "FU"

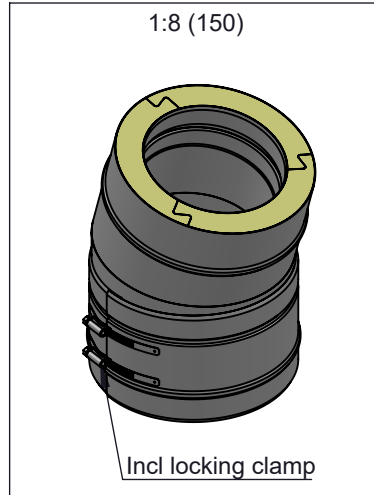
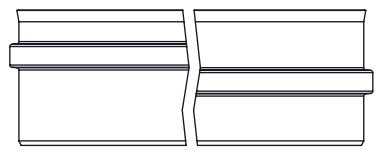

Ø	80	100	110	115	120	130	140	150	160	180	200	225	250	300	350	400	450	500	550	600
A	80	100	110	115	120	130	140	150	160	180	200	225	250	300	350	400	450	500	550	600
B	145	165	175	180	185	195	205	215	225	245	265	290	315	365	415	465	515	565	615	665
C	179	182	183	184	184	186	187	188	189	192	195	198	201	208	214	221	227	233	240	246
D	16			17						18			19	20	21	21	22	23	24	25
E	120	121	122		123	124	124	125	126	128	129	131	134	137	141	144	147	151	154	
kg	1,3	1,6	1,7	1,8	1,8	1,9	2	2,2	2,3	2,5	2,8	3,1	3,5	4,1	4,8	5,6	6,4	7,2	8	8,8

notes:

DIN ISO 13920 Tolerances B	
revisions-no.	A
date	05.11.20
name	JMA
checked by	SWA
approved by	JWY
modified by	

 CHIMNEY SYSTEMS		description	Elbow 15°
		code	DW16
		drawing-no.	01-02-20-6001-000

scale	1:5
format	A4
sheet	1 of 1