

A

B

C

D

E

F

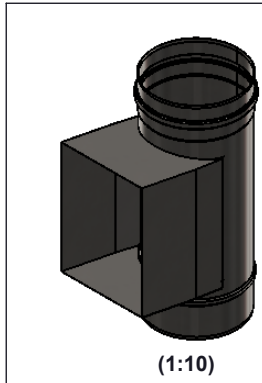
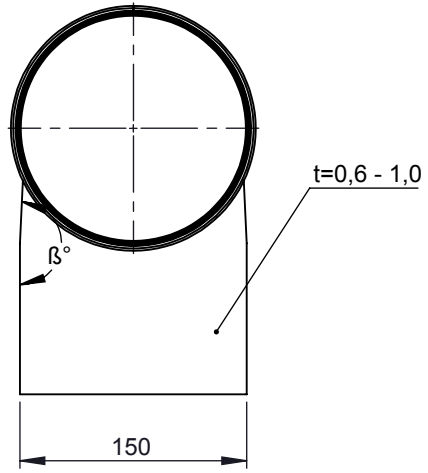
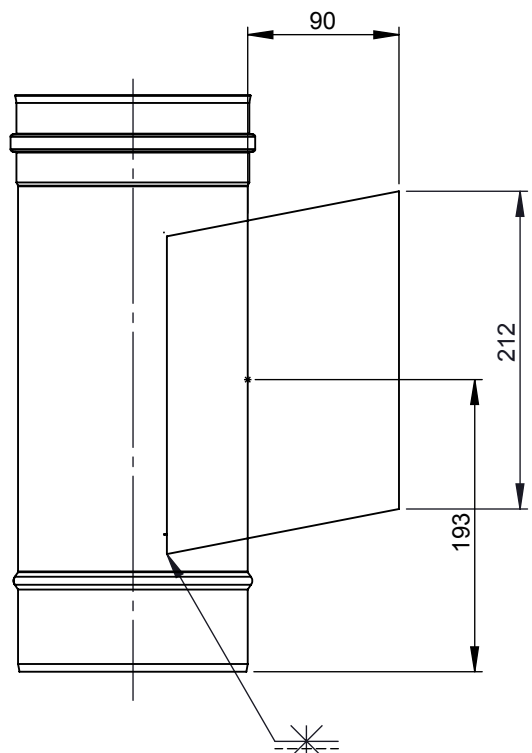
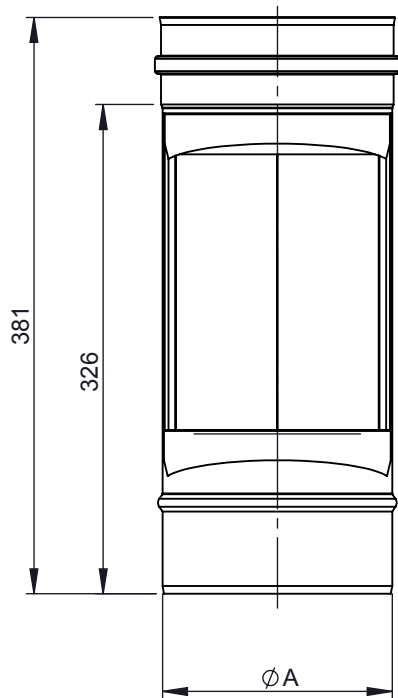

P < 0 Pa

600°C

Ö,G,F

Ø	0080	0100	0110	0115	0120	0130	0140	0150	0160	0180	0200	0225	0250	0300	0350	0400	0450	0500	0550	0600
A	80	100	110	115	120	130	140	150	160	180	200	225	250	300	350	400	450	500	550	600
β°	124°	140,8°	149,2°	153,5°	157,4°	164,9°	171,5°	177,2°	180°											
t	0,6																			
kg	0,86	0,95	1,00	1,02	1,05	1,1	1,15	1,21	1,26	1,37	1,48	1,62	1,76	2,05	2,33	2,62	2,92	3,2	3,5	3,79

<small>material:</small> inside/outside	316L	<small>surface:</small> inside/outside	3C	<small>revisions-no.</small>	Rev	Jeremias CHIMNEY SYSTEMS	<small>Scale</small>	1:5	
				<small>date</small>	<small>name</small>	<small>description</small> EW-EW 07 Reinigungselement 210x140mm	<small>Format</small>	A4	
				<small>drawn</small>	18.12.2009		FST	<small>Sheet</small>	1
	A3	02.11.2015	KAB	<small>checked</small>					
	A2	17.02.2014	JGR	<small>checked</small>					
				<small>checked</small>		<small>code</small>	EW-EW 07		
				<small>appr.</small>		<small>drawing-no.</small>			
<small>revision</small>	<small>date</small>	<small>name</small>	All rights reserved!						