

A

B

C

D

E

F

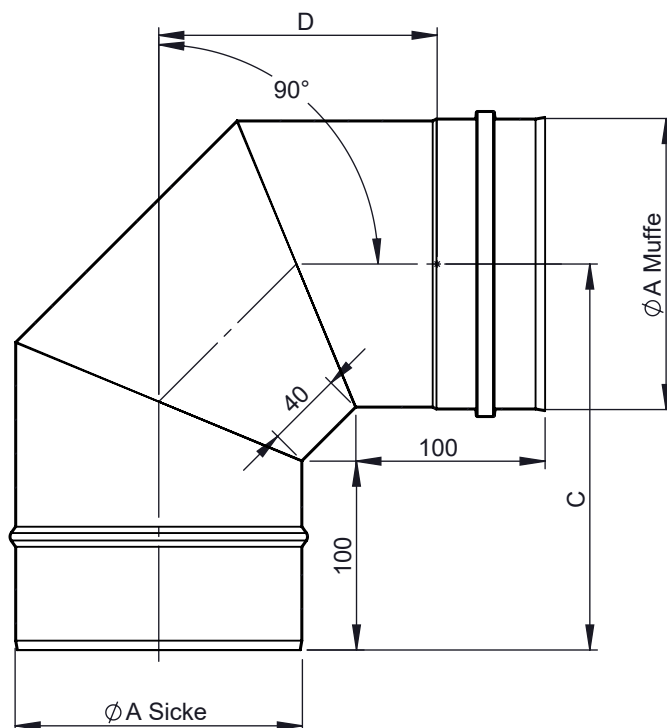

M 1:6 (Ø150)



Ø	80	100	110	115	120	125	130	140	150	160	180	200	225	250	300	350	400	450	500	550	600
A	80	100	110	115	120	125	130	140	150	160	180	200	225	250	300	350	400	450	500	550	600
C	169	179	184	186	189	191	194	199	204	209	219	229	241	254	279	304	329	354	379	404	429
D	112	122	127	129	132	134	137	142	147	152	162	172	184	197	222	247	272	297	322	347	372
kg	0,39	0,51	0,57	0,61	0,64	0,67	0,71	0,78	0,86	0,93	1,09	1,26	1,49	1,73	2,26	2,86	3,51	4,23	5,02	5,86	6,77

notes:

DIN ISO 13920 Tolerances B

revisions-no.

A3

mm / kg

date

name

drawn by

09.11.2017

KAB

checked by

approved by

modified by

24.03.2021

TRA

Jeremias®
 CHIMNEY SYSTEMS
description **Winkel 90° starr**code **FU0629N150 Ø**drawing-no. **01-01-20-6250-000**

scale

1:4

format

A4

sheet

1 of 1

