

A

B

C

D

E

F

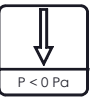
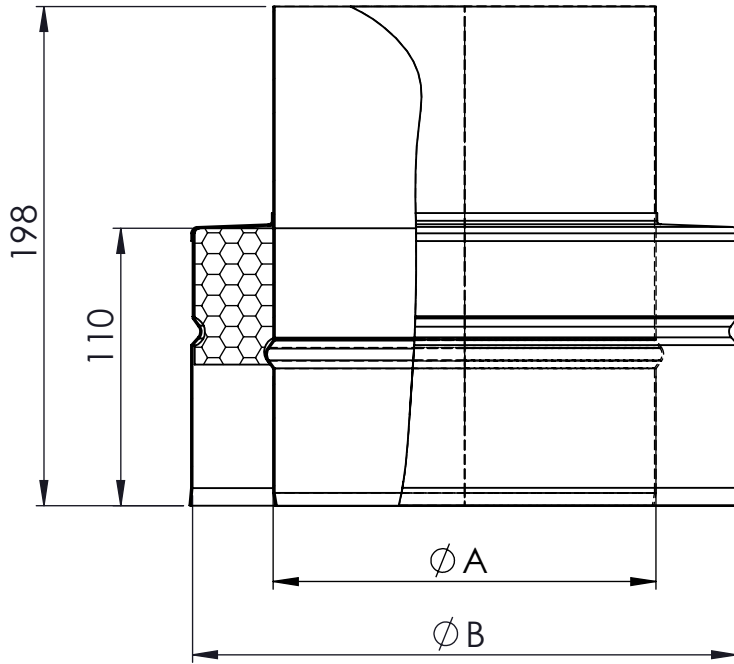

↑ Rauchgasrichtung
flue gas

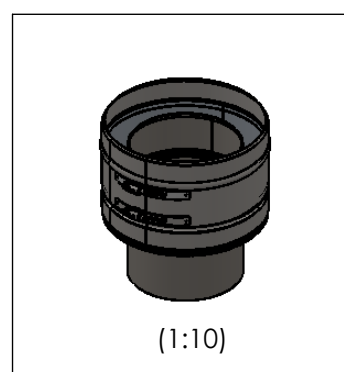
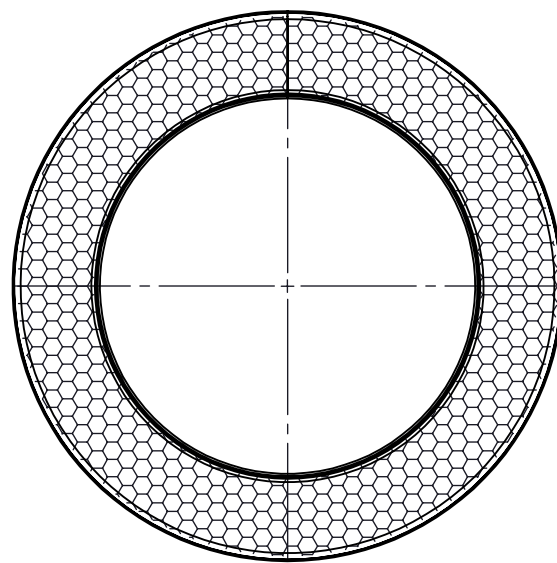

Ø	0080	0100	0115	0120	0130	0140	0150	0160	0180	0200	0225	0250	0300	0350	0400	0450	0500	0550	0600
A	80	100	115	120	130	140	150	160	180	200	225	250	300	350	400	450	500	550	600
B	145	165	180	185	195	205	215	225	245	265	290	315	365	415	465	515	565	615	665
t _i /t _a	0,6/0,6																		
kg	0,61	0,73	0,82	0,84	0,9	0,96	1,02	1,08	1,19	1,31	1,45	1,6	1,89	2,18	2,47	2,6	3,05	3,34	3,63

material: inside/outside		surface: inside/outside		weight:	
316L/304		3C/3D		revisions-no. A1	
				date	
				08.03.2010	
				name	
				F. Steingruber	
				checked	
				appr.	
A1		11.07.2012		E. Sucu	
revision		date		name	

Jeremias[®]

description DW-FU 37a Übergang dw - ew

code DWFU.6C4D01.37A Ø

drawing-no. A4

scale: 1:3

sheet 1 of 1