

M 1:15 (Ø150)

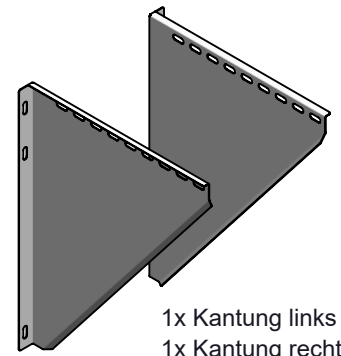

Ø	80	100	110	115	120	130	140	150	160	180	200	225	250
C	600						635			665		715	
D	475						495			525	545		595
E	18,5												
n	9									10	11		12
t	1,5												
kg	4,6	4,6	4,6	4,6	4,6	4,6	4,6	5,1	5,1	5,5	5,7	5,7	6,6

notes:

DIN ISO 13920 Tolerances B

revisions-no.

A2

mm / kg

date

17.04.2018

name

FBA

checked by

approved by

modified by

22.10.2018

FBA

Jeremias[®]
CHIMNEY SYSTEMS

description
Konsolbleche, verstellbar
von 250 - 360mm
bis Ø250

code

DW49

drawing-no.

01-02-20-0052-000

scale

1:8

format

A4



sheet

1 of 2

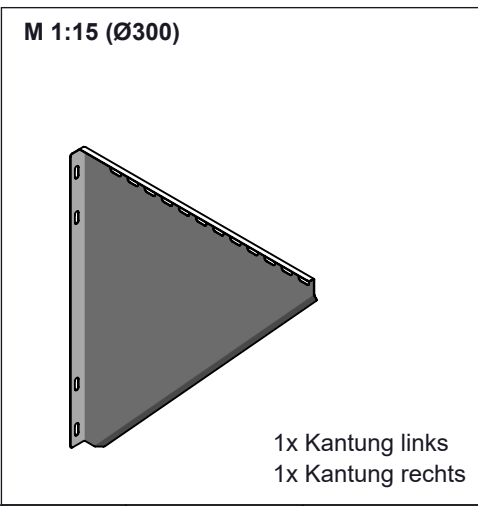
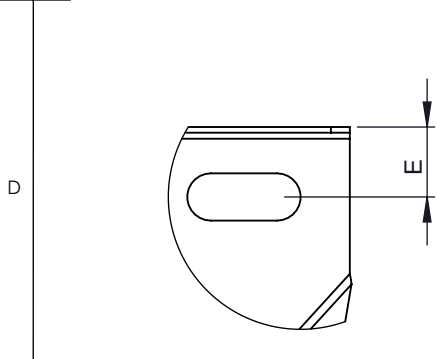
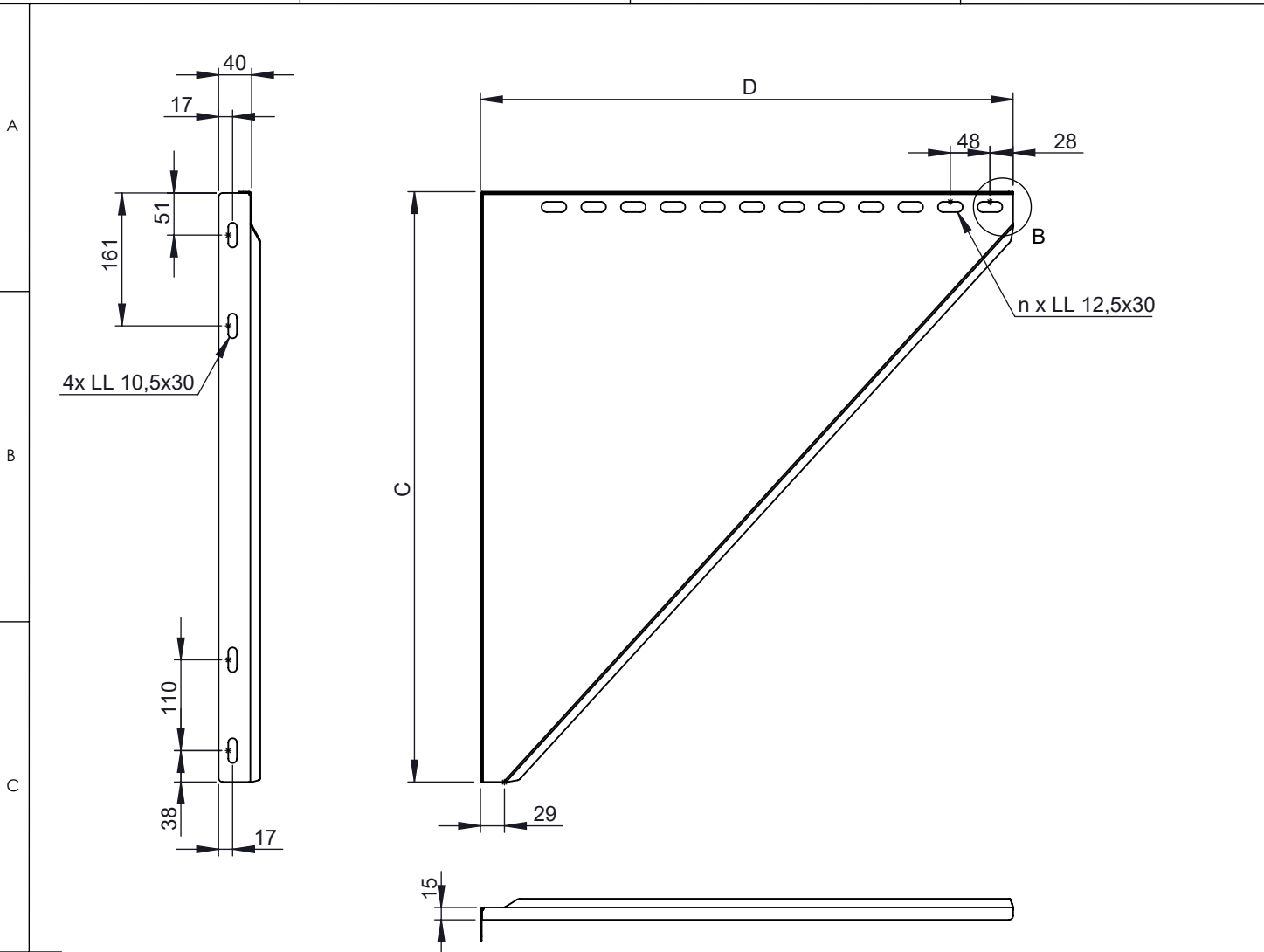



Ø	300	350	400	450	500	550	600
C	715	765	815	865	915	965	
D	645	695	745	795	845	895	945
E	18,5					19	
n	13	14	15	16	17	18	19
t	1,5					2	
kg	7	8	8,5	9,5	14,2	16,5	17,3

notes:	DIN ISO 13920 Tolerances B			 Jeremias [®] CHIMNEY SYSTEMS	scale	
	revisions-no. A2		mm / kg		1:8	
	date	name	description Konsolbleche, verstellbar von 250 - 360mm ab Ø300		format	
	drawn by	17.04.2018			FBA	A4
	checked by					sheet
	approved by					2 of 2
modified by	22.10.2018	FBA	code			
			drawing-no.			
				01-02-20-0052-000		