

Possible type of female part "FU"

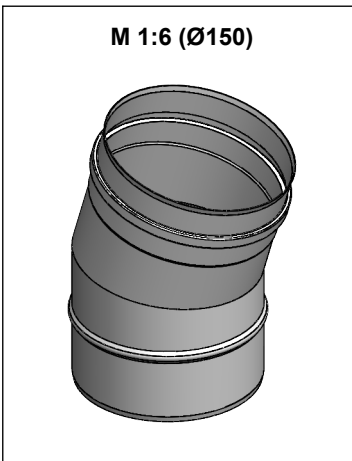
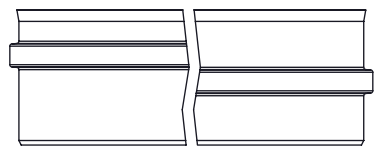

Ø	060	080	090	100	110	115	120	125	130	140	150	160	180	190	200	225	250	300	350	400	450	500	550	600
A	60	80	90	100	110	115	120	125	130	140	150	160	180	190	200	225	250	300	350	400	450	500	550	600
C	149	152	153	155	156	157	157	158	158	160	161	162	165	166	168	171	174	180	187	193	200	206	213	219
D	12	13						14						15			16	17	18	19	20	21	21	
E	104	105	106	107	107	108			109	109	110	111	112	113	113	115	117	120	123	126	130	133	136	140
kg	0,2	0,3	0,3	0,3	0,4	0,4	0,4	0,4	0,4	0,5	0,5	0,6	0,6	0,7	0,7	0,8	0,9	1,1	1,8	2,1	2,4	2,8	3,1	3,5

notes:
ENCD

DIN ISO 13920 Tolerances B		
revisions-no.	A	
	date	name
drawn by	24.10.20	AKO
checked by	24.10.20	SWA
approved by	24.10.20	JWY
modified by	10.11.21	AKO

Jeremias[®]
CHIMNEY SYSTEMS

description: Elbow 15° (TIG-welded)

code: **FU17**

drawing-no.: **01-20-6001-000**

scale	1:2.5
format	A4
sheet	1 of 1