

A

B

C

D

E

F

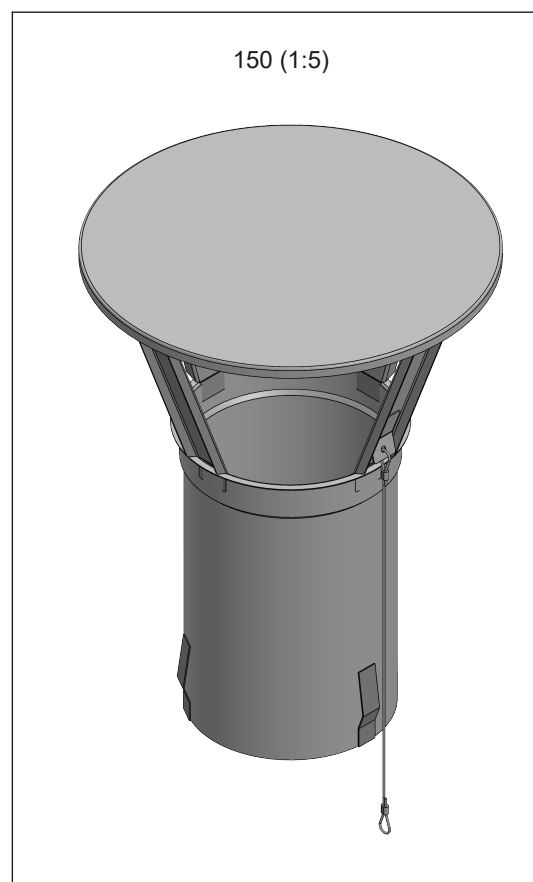
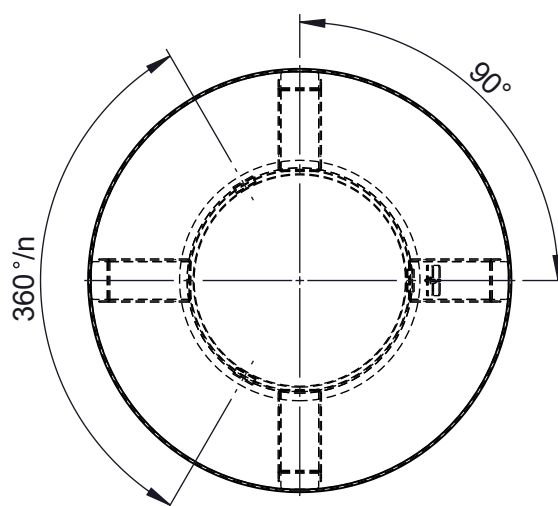
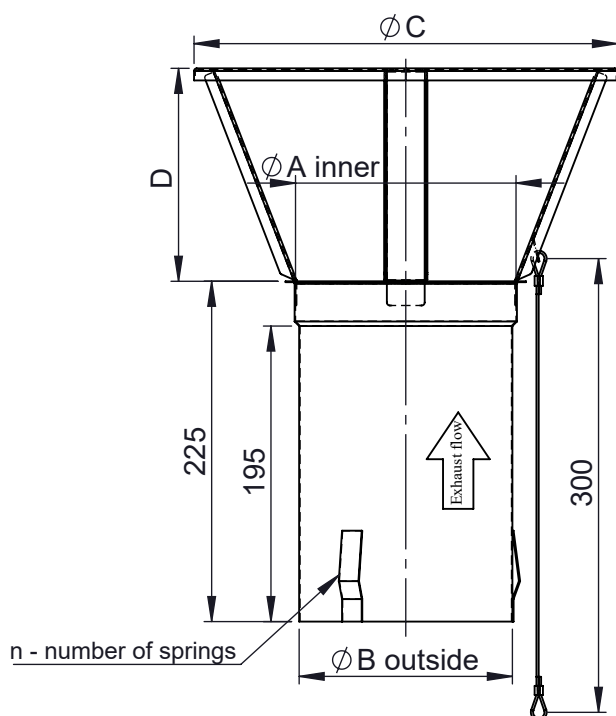

Ø	80	100	110	115	120	125	130	140	150	160	180	200	225	250	300	350	400	450	500	600
A	77	97	107	112	117	122	127	137	147	157	177	197	222	247	297	347	397	447	497	597
B	71	91	101	106	111	116	121	131	141	151	171	191	216	241	291	341	391	441	491	591
C	160	200		220			240		280		330	380	410	430	480	530	580	630	650	730
D	100					140					180			250						
n	3																		5	6
kg	0,6	0,7	0,7	0,8	0,8	0,8	1,0	1,0	1,1	1,2	1,4	1,7	2,0	2,2	2,6	3,0	3,5	4,0	4,3	5,2

notes:

ENCD

DIN ISO 13920 Tolerances B

revisions-no.

02

mm / kg

date

12.04.24

name

PMA

checked by

12.04.24

JAD

approved by

12.04.24

JWY

modified by

**Jeremias**<sup>®</sup>  
CHIMNEY SYSTEMS

description Plug-in rain cap with claws and lifeline 300mm

code **FU1265** Ø

drawing-no. **01-20-5101-000**

scale

1:5

format

A4

sheet

1 of 1

