

A

B

C

D

E

F

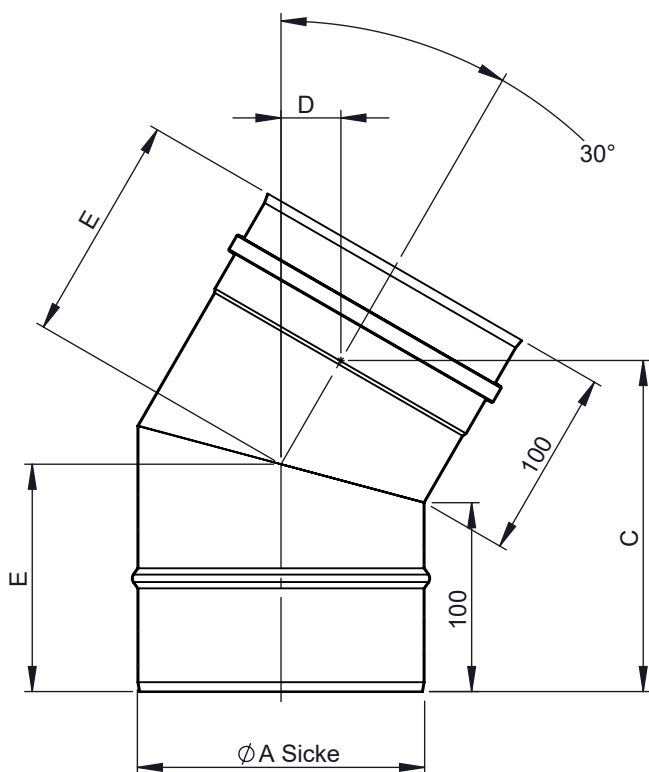

M 1:6 (Ø150)

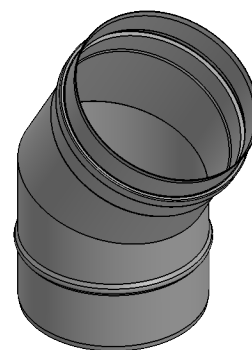

Ø	80	100	110	115	120	125	130	140	150	160	180	200	225	250	300	350	400	450	500	550	600
A	80	100	110	115	120	125	130	140	150	160	180	200	225	250	300	350	400	450	500	550	600
C	158	163	165	166	168	169	170	173	175	178	183	188	194	200	213	225	238	250	263	275	288
D	27	28	29		30			31	32		34	35	37	38	42	45	48	52	55	58	62
E	111	114	115	116		117	118	119	120	122	124	127	130	134	140	147	154	160	167	174	181
kg	0,28	0,36	0,4	0,42	0,44	0,46	0,48	0,53	0,57	0,61	0,71	0,8	0,92	1,05	1,32	1,61	1,92	2,24	2,59	2,96	3,35

notes:

DIN ISO 13920 Tolerances B

revisions-no.

A3

mm / kg

date

14.02.2018

name

KAB

checked by

approved by

modified by

23.02.2021

TRA

Jeremias[®]
CHIMNEY SYSTEMS

description **Winkel 30° starr**code **FU0618N**drawing-no. **01-01-20-6050-000**

scale

1:4

format

A4

sheet

1 of 1

